

NOTE:
 SIZE WIDTH OF DE-BONDING TAPE TO PROVIDE UN-ADHERED AREA MINIMUM 5 TIMES LARGER THAN THE MAXIMUM ANTICIPATED EXPANSION. MEMBRANE COVER STRIP MUST EXTEND PAST DE-BONDING TAPE 2" MINIMUM ALL SIDES (TYP.)

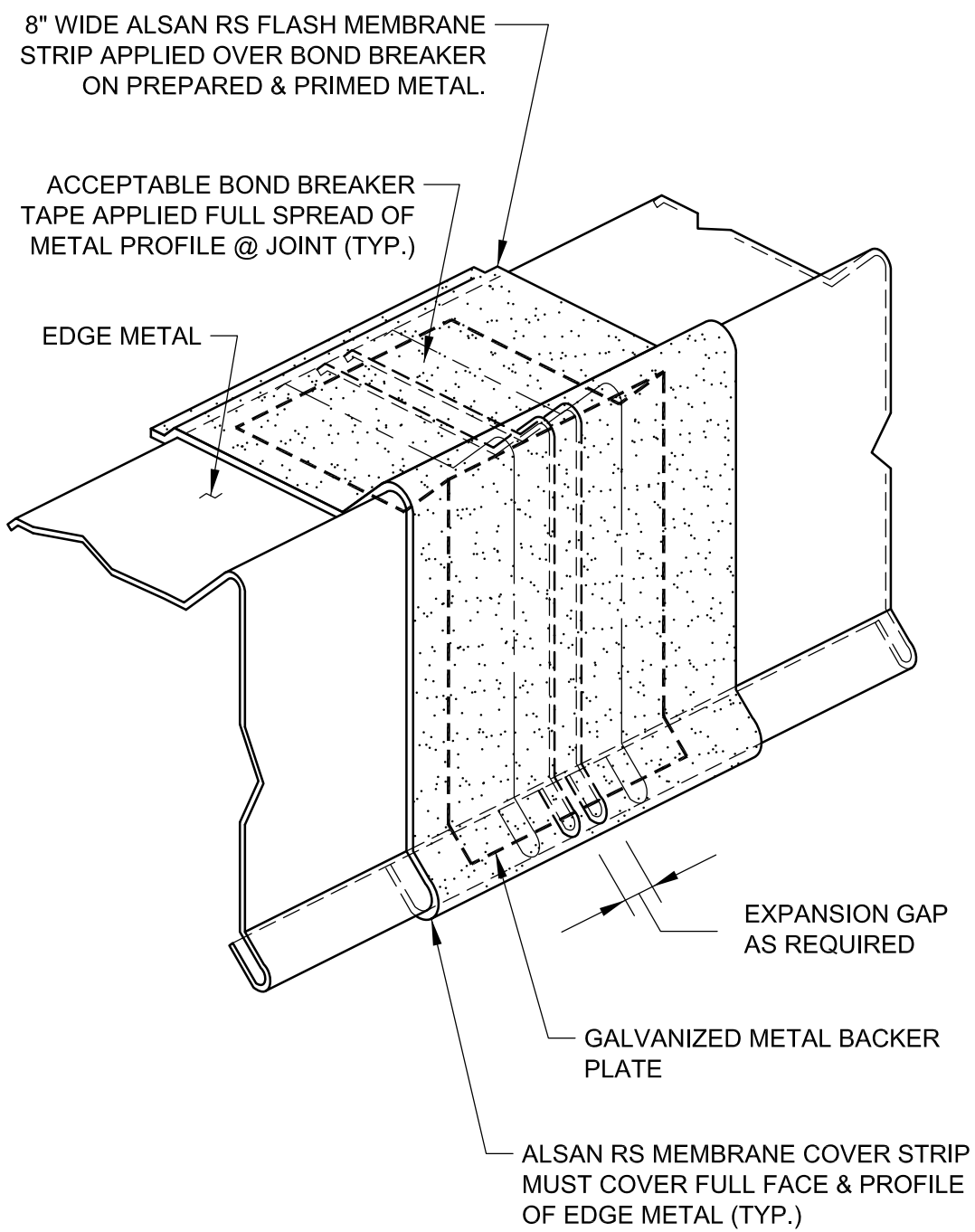

NOTE: REFER TO SOPREMA RELATED PUBLISHED DOCUMENTATION, PRODUCT DATA SHEETS (PDS) & SAFETY DATA SHEETS (SDS) FOR ADDITIONAL INFORMATION. ALL DETAIL DRAWINGS & RELATED INSTALLATION GUIDELINES ARE PROVIDED BY SOPREMA FOR THE SOLE PURPOSE OF SOPREMA WARRANTY QUALIFICATION. ACCORDINGLY, ANY DETAILS DRAWINGS PROVIDED ARE NOT OFFERED AND SHOULD NOT BE CONSIDERED A SUBSTITUTE FOR PROFESSIONAL DESIGN SERVICES. USAGE OF THIS DRAWING IS GOVERNED BY THE TERMS OF SERVICE FOR SOPREMA DETAIL, PLEASE CONSULT THESE TERMS OF SERVICE PRIOR TO UTILIZING THIS DRAWING.

310 QUADRAL DRIVE
 WADSWORTH, OHIO 44281
 (330) 334-0066

SOPREMA[®]

ALSAN RS WATERPROOFING MEMBRANE EDGE METAL EXPANSION JOINT STRIP				
REVISION	ISSUE DATE	SCALE	DRAWN BY	
0	12-15-2018	N.T.S.	DRW	

DRAWING NO.:
RS-J0A

RS_J00A