

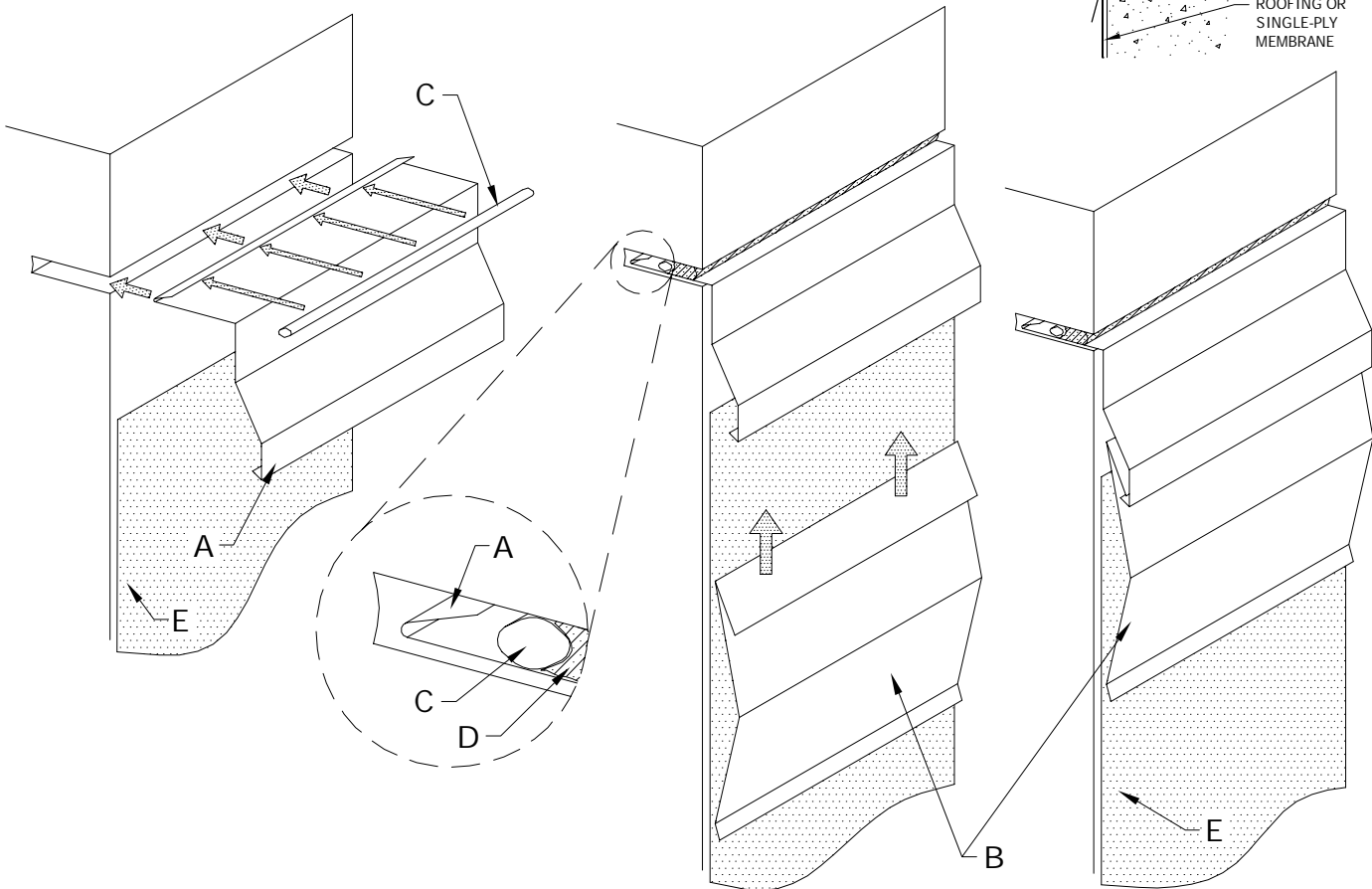

Installation Guide for In-Wall Drive-Lock Reglet

NOTES:
 #1 - Isolate all metal parts from ACQ treated wood or other galvanically incompatible material with appropriate membrane material.
 #2 - Appliance attachments, such as lightning rods, signs, or antennae that penetrate the water seal, induce a galvanic reaction, or otherwise compromise the effectiveness of the roof edge system, shall be eliminated or isolated to prevent problems per section 8.0 of ANSI/SPRI ES-1. Appliances shall be isolated from or not attached to the roof edge system. Consult the lightning protection system manufacturer for specific attachment instructions.

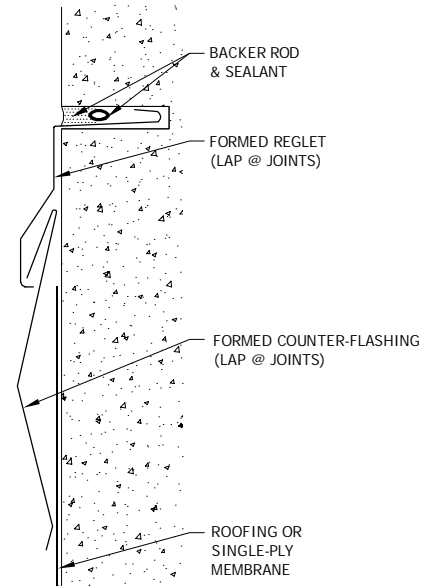

A. Formed Reglet
10'-0" Lengths

B. Formed Counter-Flashing
10'-0" Lengths

C. Backer Rod
10'-0" Lengths
(By Installer)

D. Sealant
Continuous Bead of Sealant, 3/8" Wide
(By Installer)

E. Roofing or Single-Ply Membrane
(By Installer)

SOPREMA, Inc.

310 Quadral Drive - Wadsworth, OH 44281 - Phone: (800) 356-3521 - Fax: (330) 334-4289

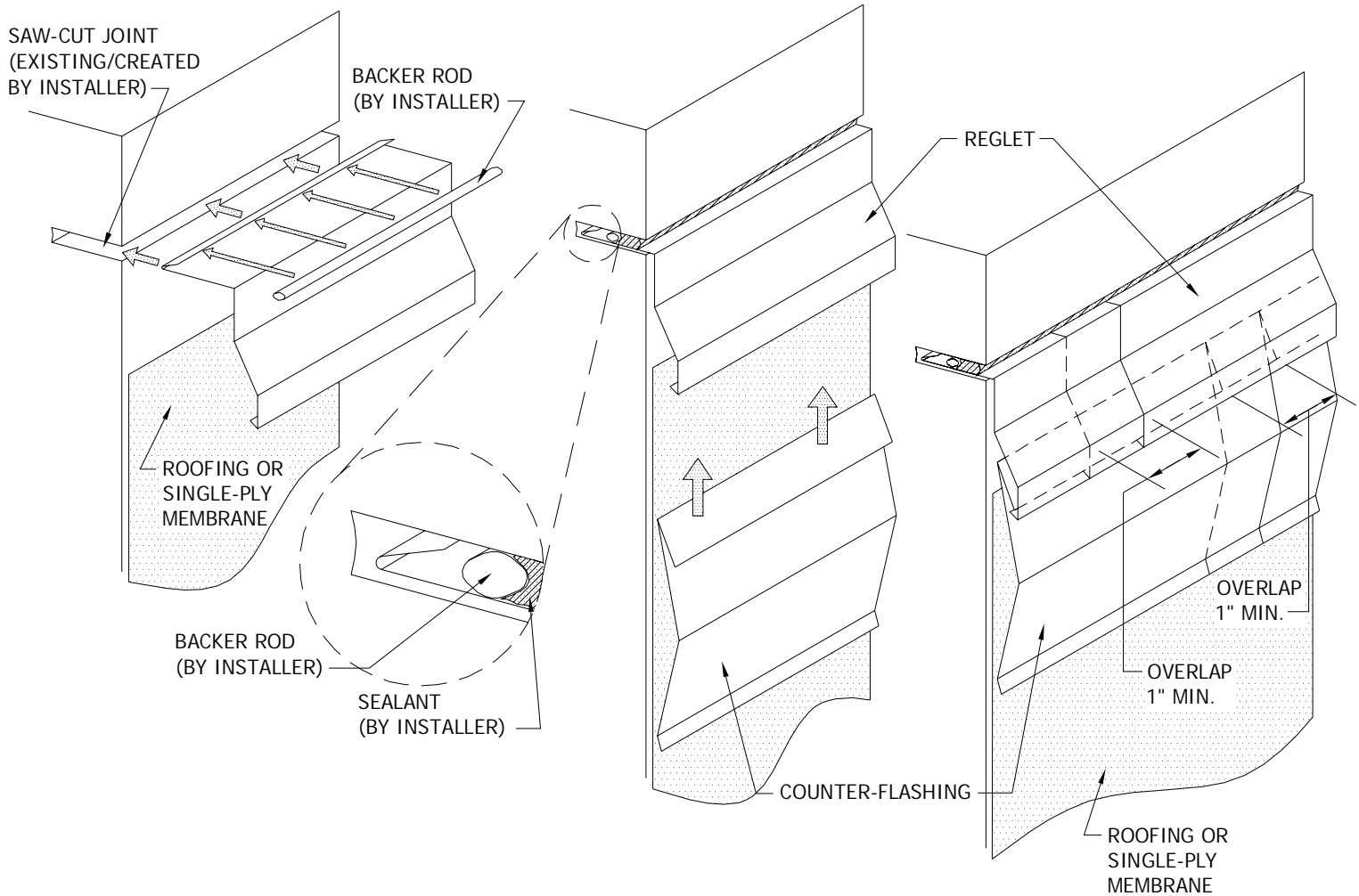

STEP 1: Installation of Reglet

Ensure that roofing membrane is continued up the side wall far enough to be covered by the reglet. Position the reglet in front of the saw-cut joint and insert by pressing firmly. Be sure to lap each adjoining piece of reglet a min. of 1" to allow for thermal expansion. After pressing the reglet into the saw-cut joint, drive the backer-rod into the saw-cut joint uniformly to secure the reglet.

STEP 2: Installation of Counter Flashing

Position the counter flashing as shown in the diagram above (parallel to the reglet). Firmly press the counter flashing upward to snap it into position. Be sure to lap each adjoining piece of counter flashing a min. of 1" to allow for thermal expansion.

STEP 3: Installation of Sealant

Apply the sealant along the entire length of the reglet sections. Be sure that the entire saw-cut joint is sealed with the sealant. The sealant should be applied up against the backer-rod (see magnified diagram above).

CORNER APPLICATION

Field bevel cut reglet and counter flashing for appropriate corner.