

**1 PER 1.3 FT<sup>2</sup> FASTENING PATTERN**

- ACTUAL ONE (1) FASTENER PER 1.23 SQUARE FEET
- TWENTY SIX (26) FASTENERS PER BOARD
- ENSURE FASTENER ENGAGES THE TOP FLANGE FOR STEEL DECK APPLICATIONS

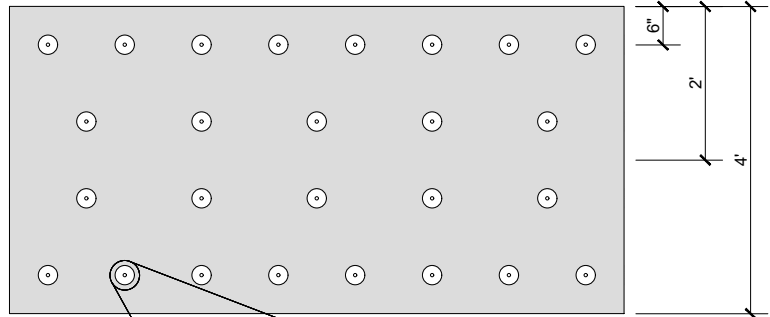
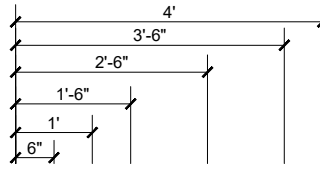

**FASTENING PATTERN FOR SHADED AREAS**

ROOF HEIGHT LESS THAN OR EQUAL TO 60ft

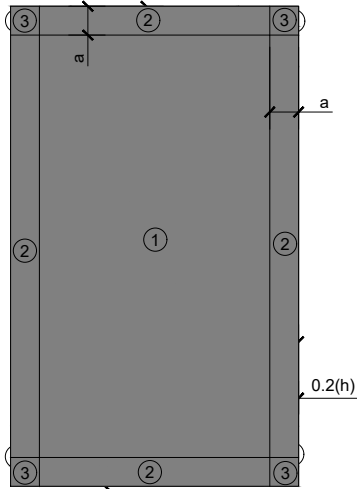

ROOF HEIGHT GREATER THAN 60ft

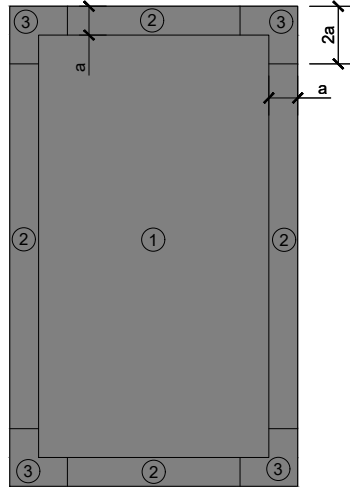

$a = 40\%$  of least horizontal dimension or 40% of eave height, whichever is smaller, but not less than either 4% of least horizontal dimension or 3ft

$a = 10\%$  of least horizontal roof dimension, but not less than 3ft

**ASCE 7-16 ROOF ZONES**  
**(LOW-SLOPE ROOF ZONES)**  
**(LOW-SLOPE ROOFS  $\theta \leq 7^\circ$ )**

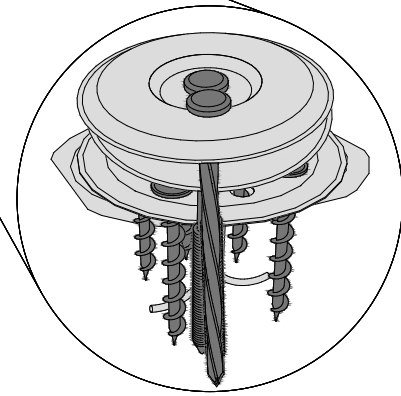

**SOPREMA FASTENERS STATE**  
**WARRANTY FOR CONCRETE**

**NOTES:**

1. SOPREMA DETAIL DRAWINGS: REFER TO SOPREMA AND OTHER RELATED PUBLISHED DOCUMENTATION, PRODUCT DATA SHEETS (PDS) AND SAFETY DATA SHEETS (SDS) FOR ADDITIONAL INFORMATION. ALL DETAIL DRAWINGS AND RELATED INSTALLATION GUIDELINES ARE PROVIDED BY SOPREMA FOR THE SOLE PURPOSE OF ISSUING A SOPREMA WARRANTY. ACCORDINGLY, THE DETAIL DRAWINGS ARE NOT OFFERED, AND SHOULD NOT BE CONSIDERED, AS A SUBSTITUTE FOR PROFESSIONAL DESIGN SERVICES.
2. SOPREMA NOR ITS EMPLOYEES ARE DESIGNER OF RECORD FOR ANY PROJECT. FASTENING PATTERNS PROVIDED BY SOPREMA ARE FOR SOPREMA WARRANTY PURPOSES ONLY. REFER TO LOCAL BUILDING CODES, DESIGNER OF RECORD DOCUMENTS, AND JURISDICTIONAL/AGENCY APPROVALS FOR PROJECT-SPECIFIC FASTENING REQUIREMENTS.
3. ROOF ZONE GUIDELINES PROVIDED HEREIN ARE OFFERED FOR REFERENCE. REFER TO ASCE/SEI 7 FOR SPECIFIC REQUIREMENTS.



US CORPORATE ADDRESS  
310 QUADRAL DRIVE  
WADSWORTH, OHIO 44281  
www.soprema.us  
Tel: 330.334.0066

PROJECT:

TITLE:

**1 FASTENER PER 1.3 FT<sup>2</sup>,  
4X8 BOARD FASTENING PATTERN**

DRAWN BY: SOPREMA TECHNICAL SUPPORT, GGALLOWAY

NO.:

REVISION:

DATE:

DATE: 4.20.2020

SCALE: NTS

DRAWING NUMBER:  
**US.FP.04.11**