

**ZONE 1**

- ONE (1) ROW WITHIN THE CENTER OF THE SIDE LAPS SPACED 24" O.C.

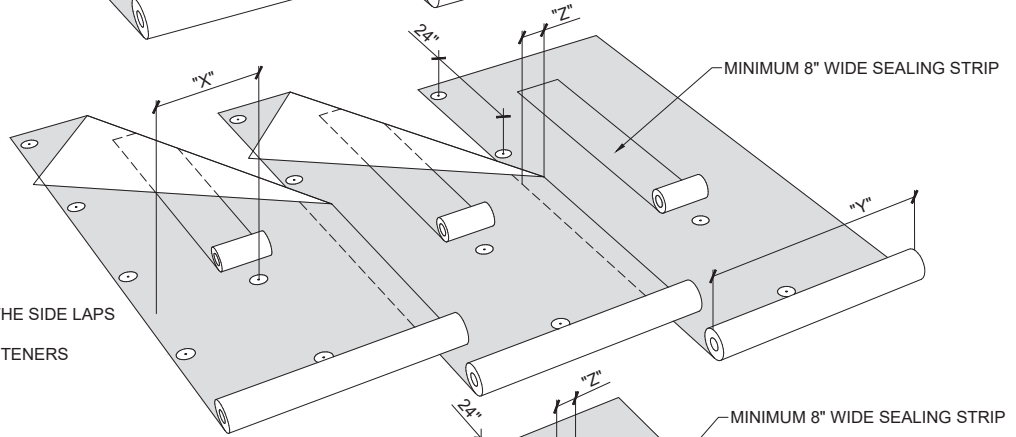

**ZONE 2**

- NOMINAL 60% OF FIELD ROW SPACING
- ONE (1) ROW WITHIN THE CENTER OF THE SIDE LAPS SPACED 24" O.C.
- ONE (1) INTERMEDIATE ROW, WITH FASTENERS SPACED 24" O.C. AND STAGGERED

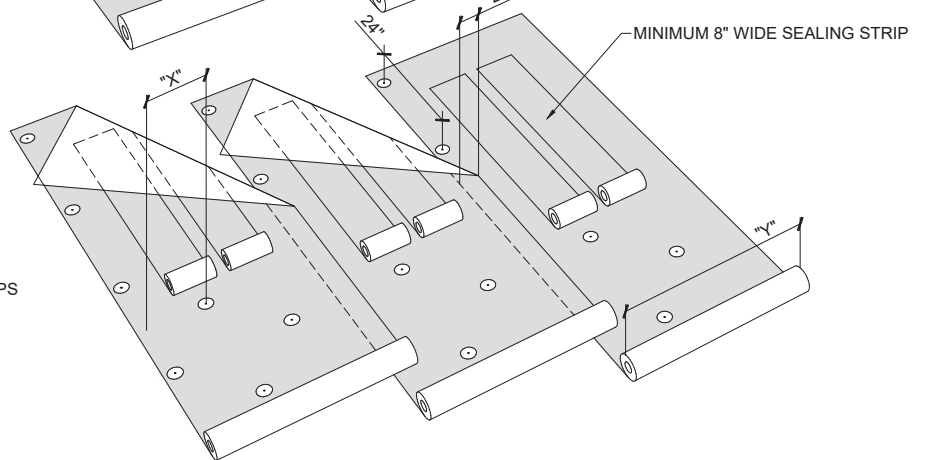

**ZONE 3**

- NOMINAL 40% OF FIELD ROW SPACING
- ONE (1) ROW WITHIN THE CENTER OF THE SIDE LAPS SPACED 24" O.C.
- TWO (2) INTERMEDIATE ROWS, WITH FASTENERS SPACED 24" O.C. AND STAGGERED

| Roll Width (Y) | Lap Width (Z) | Zone | Pattern  | Row Spacing (X) | Fasteners Per Square |
|----------------|---------------|------|----------|-----------------|----------------------|
| 39in (1m)      | 4in           | 1    | 24       | 35in            | 18                   |
|                |               | 2    | 24,24    | 17.5in          | 35                   |
|                |               | 3    | 24,24,24 | 11.67in         | 52                   |
| 39in (1m)      | 5in           | 1    | 24       | 34in            | 18                   |
|                |               | 2    | 24,24    | 17in            | 36                   |
|                |               | 3    | 24,24,24 | 11.33in         | 53                   |
| 39in (1m)      | 6in           | 1    | 24       | 33in            | 19                   |
|                |               | 2    | 24,24    | 16.5in          | 37                   |
|                |               | 3    | 24,24,24 | 11in            | 55                   |

NOTES:

1. SOPREMA DETAIL DRAWINGS: REFER TO SOPREMA AND OTHER RELATED PUBLISHED DOCUMENTATION, PRODUCT DATA SHEETS (PDS) AND SAFETY DATA SHEETS (SDS) FOR ADDITIONAL INFORMATION. ALL DETAIL DRAWINGS AND RELATED INSTALLATION GUIDELINES ARE PROVIDED BY SOPREMA FOR THE SOLE PURPOSE OF ISSUING A SOPREMA WARRANTY. ACCORDINGLY, THE DETAIL DRAWINGS ARE NOT OFFERED, AND SHOULD NOT BE CONSIDERED, AS A SUBSTITUTE FOR PROFESSIONAL DESIGN SERVICES.
2. SOPREMA NOR ITS EMPLOYEES ARE DESIGNER OF RECORD FOR ANY PROJECT. FASTENING PATTERNS PROVIDED BY SOPREMA ARE FOR SOPREMA WARRANTY PURPOSES ONLY. REFER TO LOCAL BUILDING CODES, DESIGNER OF RECORD DOCUMENTS, AND JURISDICTIONAL/AGENCY APPROVALS FOR PROJECT-SPECIFIC FASTENING REQUIREMENTS.



US CORPORATE ADDRESS  
 310 QUADRAL DRIVE  
 WADSWORTH, OHIO 44281  
 www.soprema.us  
 Tel:330.334.0066

PROJECT:

TITLE: MECHANICALLY ATTACHED BASE PLY,  
 24" O.C. IN LAP FASTENING PATTERN  
 AND PRESCRIPTIVE ENHANCEMENTS

DRAWN BY: SOPREMA TECHNICAL SUPPORT, GGALLOWAY

NO.:

REVISION:

DATE:

DATE: 12.23.2019

SCALE: NTS

DRAWING NUMBER:  
**US.FP.16.01**