

DRAWING MUST BE VIEWED IN ADOBE ACROBAT TO ENABLE CUSTOM LAYERING

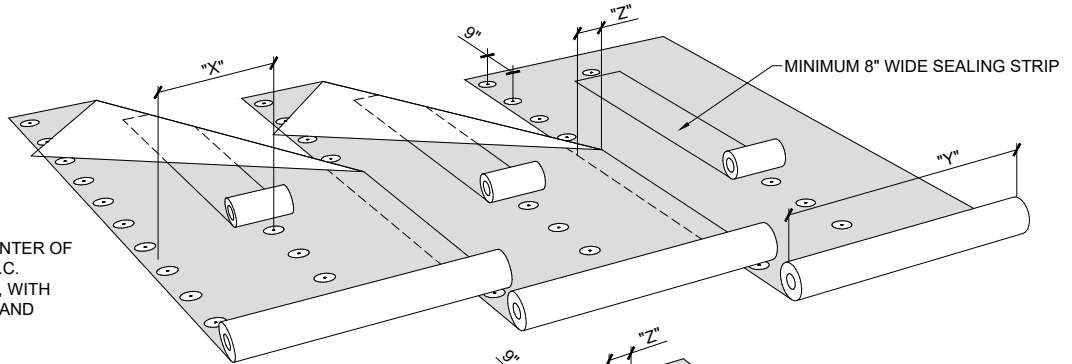

ZONE 1

- ONE (1) ROW WITHIN THE CENTER OF THE SIDE LAPS SPACED 9" O.C.
- ONE (1) INTERMEDIATE ROW, WITH FASTENERS SPACED 9" O.C. AND STAGGERED

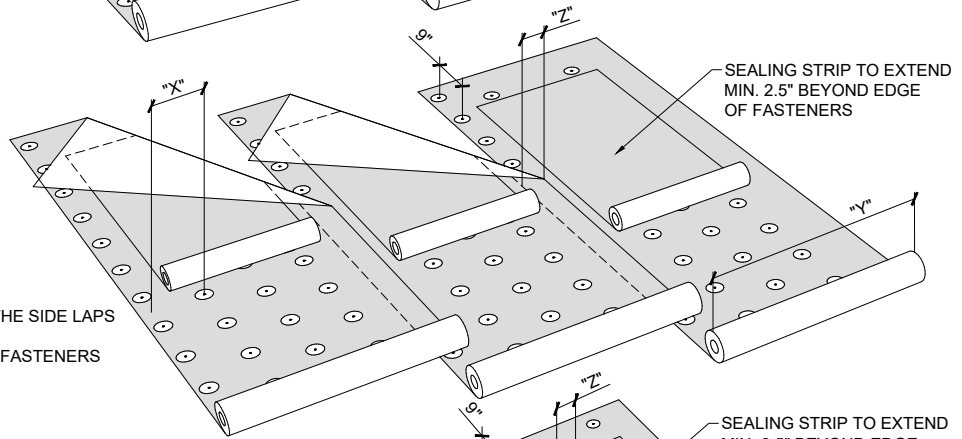

ZONE 2

- NOMINAL 60% OF FIELD ROW SPACING
- ONE (1) ROW WITHIN THE CENTER OF THE SIDE LAPS SPACED 9" O.C.
- THREE (3) INTERMEDIATE ROWS, WITH FASTENERS SPACED 9" O.C. AND STAGGERED

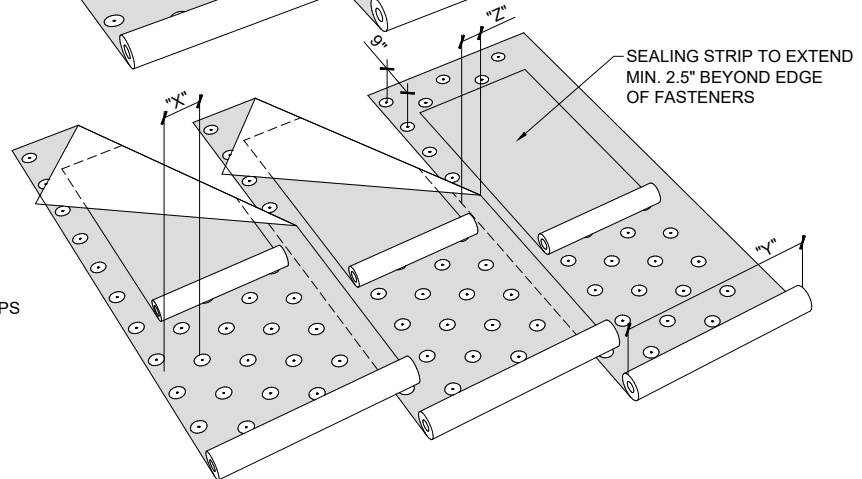

ZONE 3

- NOMINAL 40% OF FIELD ROW SPACING
- ONE (1) ROW WITHIN THE CENTER OF THE SIDE LAPS SPACED 9" O.C.
- FOUR (4) INTERMEDIATE ROWS, WITH FASTENERS SPACED 9" O.C. AND STAGGERED

Roll Width (Y)	Lap Width (Z)	Zone	Pattern	Row Spacing (X)	Fasteners Per Square
39in (1m)	4in	1	9,9	17.5in	92
		2	9,9,9,9	8.75in	183
		3	9,9,9,9,9	7in	229
39in (1m)	5in	1	9,9	17in	95
		2	9,9,9,9	8.5in	189
		3	9,9,9,9,9	6.8in	236
39in (1m)	6in	1	9,9	16.5in	97
		2	9,9,9,9	8.25in	194
		3	9,9,9,9,9	6.6in	243

NOTES:

1. SOPREMA DETAIL DRAWINGS: REFER TO SOPREMA AND OTHER RELATED PUBLISHED DOCUMENTATION, PRODUCT DATA SHEETS (PDS) AND SAFETY DATA SHEETS (SDS) FOR ADDITIONAL INFORMATION. ALL DETAIL DRAWINGS AND RELATED INSTALLATION GUIDELINES ARE PROVIDED BY SOPREMA FOR THE SOLE PURPOSE OF ISSUING A SOPREMA WARRANTY. ACCORDINGLY, THE DETAIL DRAWINGS ARE NOT OFFERED, AND SHOULD NOT BE CONSIDERED, AS A SUBSTITUTE FOR PROFESSIONAL DESIGN SERVICES.
2. SOPREMA NOR ITS EMPLOYEES ARE DESIGNER OF RECORD FOR ANY PROJECT. FASTENING PATTERNS PROVIDED BY SOPREMA ARE FOR SOPREMA WARRANTY PURPOSES ONLY. REFER TO LOCAL BUILDING CODES, DESIGNER OF RECORD DOCUMENTS, AND JURISDICTIONAL/AGENCY APPROVALS FOR PROJECT-SPECIFIC FASTENING REQUIREMENTS.



US CORPORATE ADDRESS
310 QUADRAL DRIVE
WADSWORTH, OHIO 44281
www.soprema.us
Tel: 330.334.0066

PROJECT:

TITLE: **MECHANICALLY ATTACHED BASE PLY,
9" O.C. IN LAP AND ONE ROW BETWEEN LAPS
AT 9" O.C. FASTENING PATTERN
AND PRESCRIPTIVE ENHANCEMENTS**

DRAWN BY: SOPREMA TECHNICAL SUPPORT, GGALLOWAY

NO.:	REVISION:	DATE:

DATE: 1.30.2020

SCALE: NTS

DRAWING NUMBER:
US.FP.16.21