

STEP 1

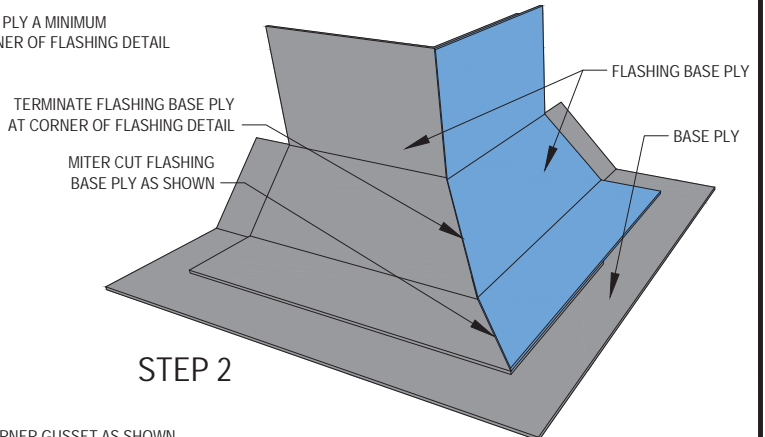

STEP 2

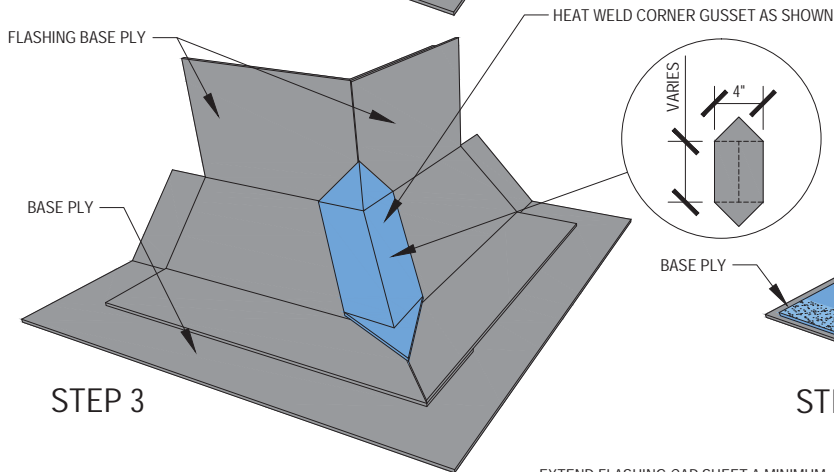

STEP 3

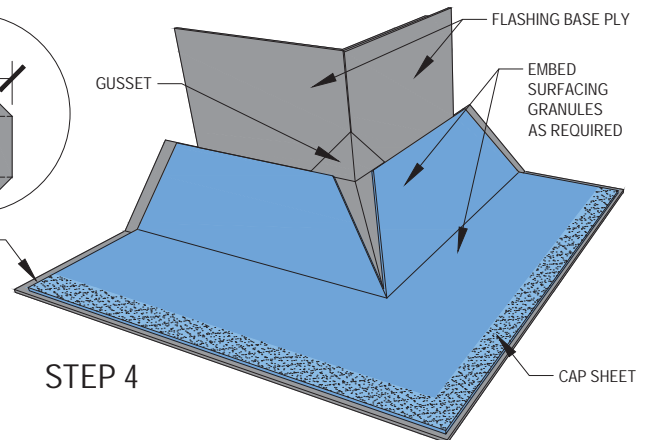

STEP 4

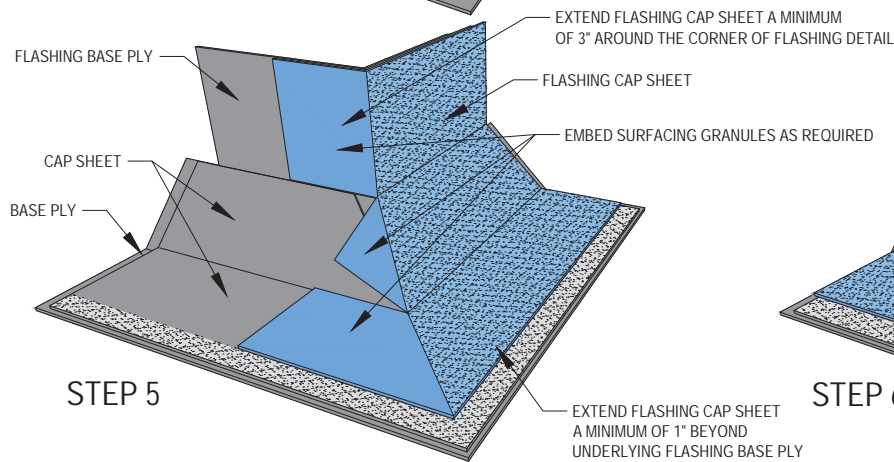

STEP 5

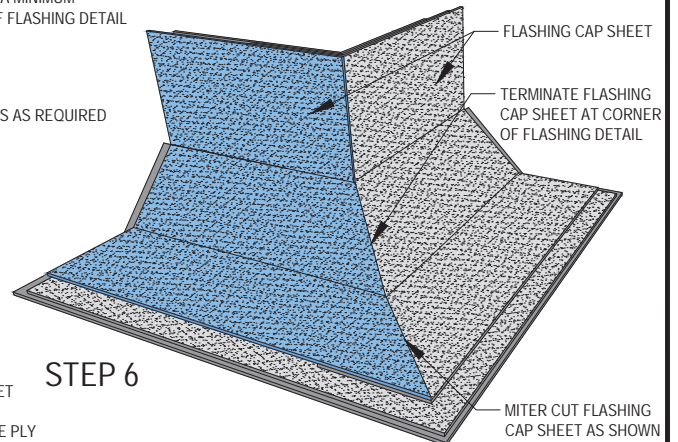

STEP 6

NOTES:

1. SOPREMA DETAIL DRAWINGS: REFER TO SOPREMA AND OTHER RELATED PUBLISHED DOCUMENTATION, PRODUCT DATA SHEETS (PDS) AND SAFETY DATA SHEETS (SDS) FOR ADDITIONAL INFORMATION. ALL DETAIL DRAWINGS AND RELATED INSTALLATION GUIDELINES ARE PROVIDED BY SOPREMA FOR THE SOLE PURPOSE OF ISSUING A SOPREMA WARRANTY. ACCORDINGLY, THE DETAIL DRAWINGS ARE NOT OFFERED, AND SHOULD NOT BE CONSIDERED, AS A SUBSTITUTE FOR PROFESSIONAL DESIGN SERVICES.
2. HOT WORK: THE CONTRACTOR IS RESPONSIBLE FOR DETERMINING APPROPRIATE CONDITIONS TO UTILIZE HEAT-WELDING EQUIPMENT. REFER TO THE NRCA CERTA RECOMMENDATIONS, LOCAL CODES AND BUILDING OWNER'S REQUIREMENTS FOR HOT WORK OPERATIONS.
3. PRIMER: WHERE NOT SHOWN OR INDICATED ON DETAIL DRAWINGS, REFER TO MATERIAL PRODUCT DATA SHEETS FOR PRIMER APPLICATION REQUIREMENTS.



US CORPORATE ADDRESS
310 QUADRAL DRIVE
WADSWORTH, OHIO 44281
www.soprema.us
Tel:330.334.0066

PROJECT:

TITLE:

2 PLY SBS MEMBRANE
OUTSIDE CORNERS

DRAWN BY: SOPREMA TECHNICAL SUPPORT, GGALLOWAY

NO.:

REVISION:

DATE:

DATE: 4.8.2016

SCALE: NTS

DRAWING NUMBER:
US.WSBS.02.13